

Posted at: 12/20

DTM

Doc No.: 4

AVL
RACETECH

BOP (v1.0)

Race 6, Spa-Francorchamps

09. - 11. September 2022

Anton Schweinzer

DTM Race 6, Spa-Francorchamps General - Event and Track Information





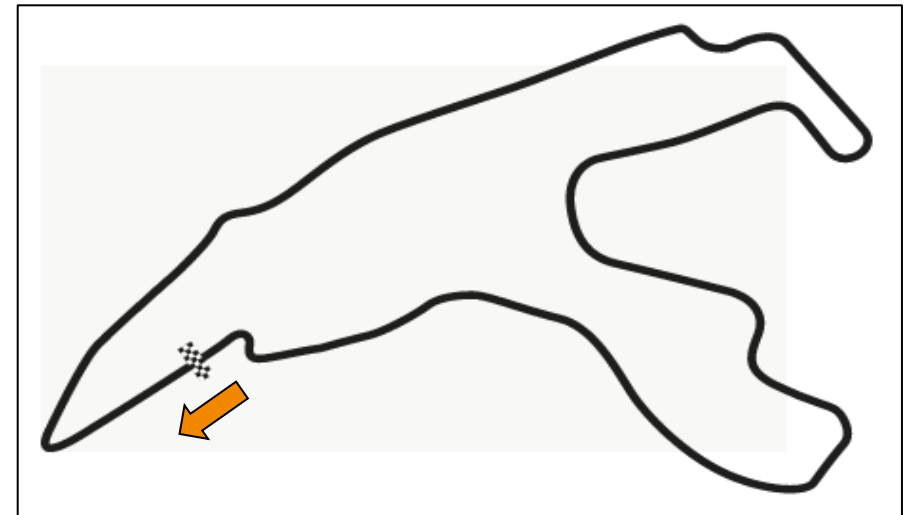

Event:	DTM Race 6
Date:	09. - 11. September 2022

Track:	Spa-Francorchamps
Track Length:	7004m
Race 1:	13:30, 10. September 2022
Race 2:	13:30, 11. September 2022



DTM Race 6, Spa-Francorchamps BoP for Engine and Car weight







DTM		Balance of Performance, V1.0				AVL RACETECH	
		DTM Race 6, Spa-Francorchamps					
9. - 11. September 2022							
Brand	Typ	Restrictor [mm]	Boost ratio @ max Power [-]	DTM Car Weight [kg]	BoP Ballast [kg]	Total Car Weight [kg]	Total with Driver [kg]
	R8	2 x 37		1310	30	1340	<u>1420</u>
	M4		2.721	1310	0	1310	<u>1390</u>
	488		1.590	1295	25	1320	<u>1400</u>
	911	2 x 48		1275	0	1275	<u>1355</u>
	Huracan	2 x 41		1295	45	1340	<u>1420</u>
	GT3	2 x 36		1325	15	1340	<u>1420</u>

Note:
 1. The DTM Car Weight includes the empty ballast box and the onboard camera.
 2. The Total Car Weight includes the BoP Ballast.



DTM Race 6, Spa-Francorchamps

BoP for P_boost Ratio

DTM		Balance of Performance, V1.0		
		DTM Race 6, Spa-Francorchamps		
9. - 11. September 2022				
P_Boost ratio for Turbo Engines				
				
n	P_boost ratio		P_boost ratio	
3000	1.486		x	
3500	1.537		2.357	
4000	1.606		2.409	
4500	1.673		2.493	
5000	1.727		2.591	
5250	x		2.637	
5500	1.751		2.683	
5750	x		2.720	
6000	1.733		2.724	
6250	x		2.721	
6500	1.662		2.648	
6750	x		2.528	
7000	1.590		2.394	
7500	1.539		x	

Note:

1. The P_boost ratio in the table has to be multiplied with the P_Ambient pressure to get the P_boost limits.
2. P_Ambient will be communicated by the Organisation.
3. Boost pressure control like FIA strategy, see next figure.
4. The interpolation between the breakpoints is linear.

DTM Race 6, Spa-Francorchamps FIA Boost Control

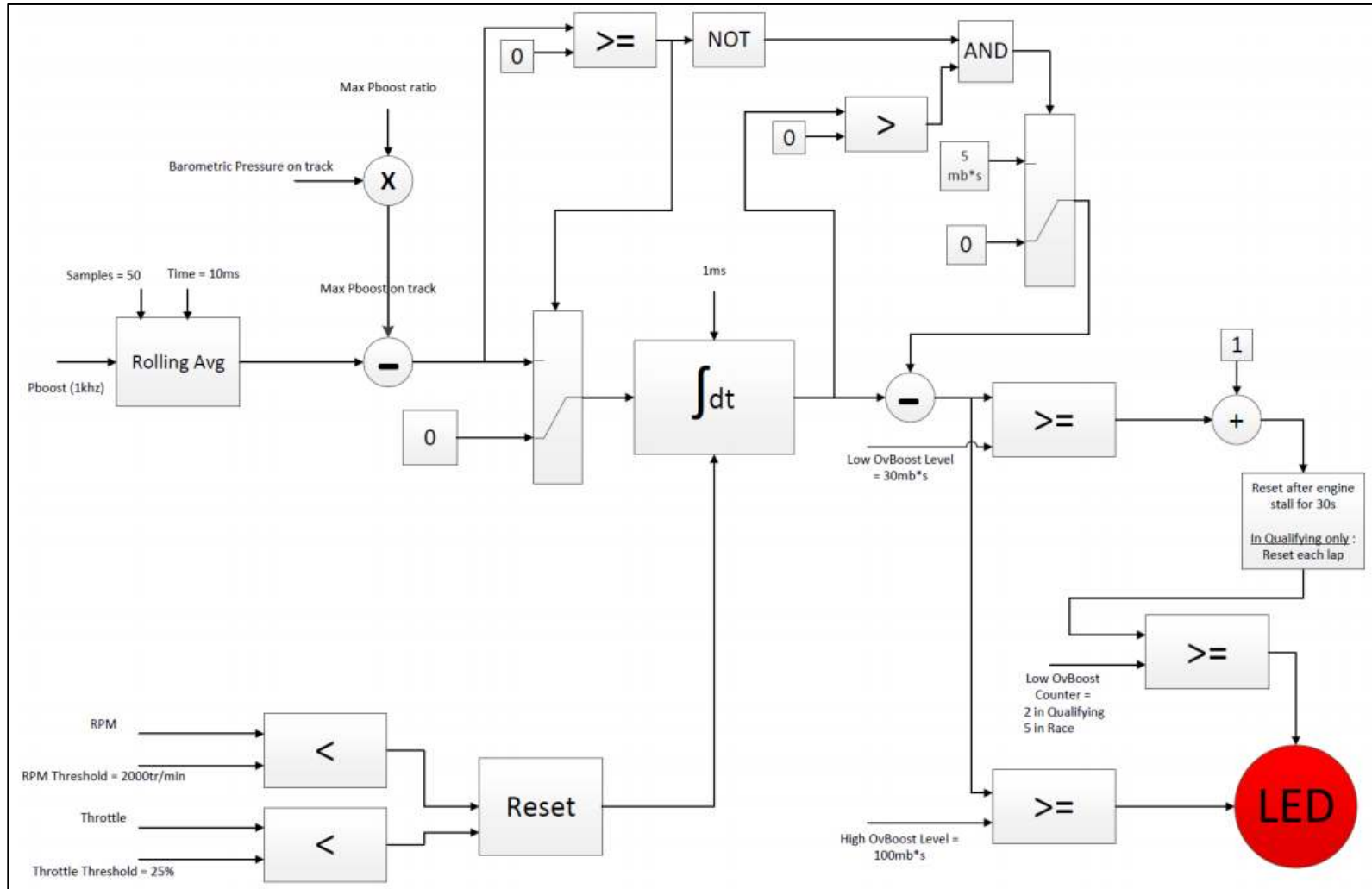

© ITR GmbH 2022. All contents of the DTM BoP 2022 are subject to the intellectual property rights of ITR GmbH and may not be used as a whole or in parts by third parties e.g. other race series or ASNs without ITR GmbH's prior written consent. The BoP parameters were created by AVL for ITR GmbH on the basis of vehicle simulation for the relevant race tracks of the DTM season 2022.