

Posted at: 10:00

**DTM**

Doc No.: 3



# **BOP (v1.0)**

## **Race 8, Hockenheim**

### **7. - 9. October 2022**

Anton Schweinzer

# DTM Race 8, Hockenheim

## General - Event and Track Information

Event:	DTM Race 8
Date:	7. - 9. October 2022



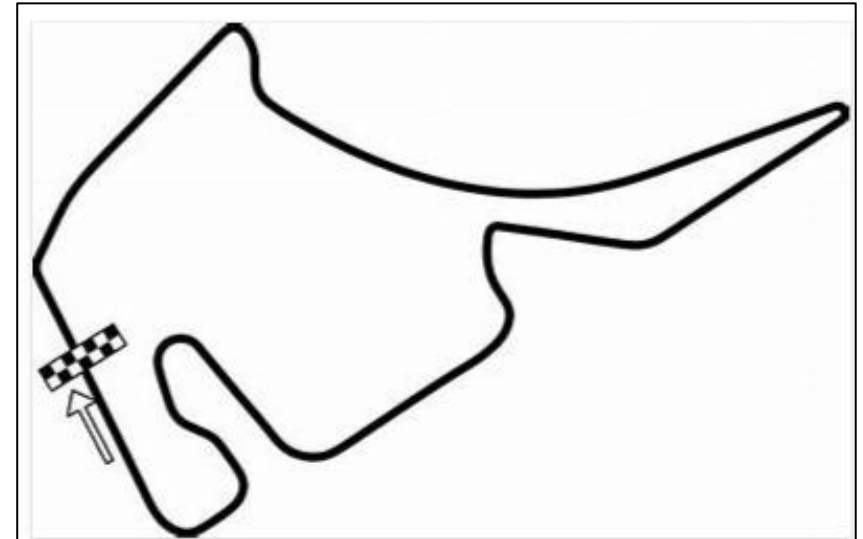





Track:	Hockenheim
Track Length:	4574m
Race 1:	13:30, 8. October 2022
Race 2:	13:30, 9. October 2022

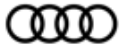

# DTM Race 8, Hockenheim

## BoP for Engine and Car weight







<b>DTM</b>		<b>Balance of Performance, V1.0</b>					
		<b>DTM Race 8, Hockenheim</b>					
7. - 9. October 2022							
Brand	Typ	Restrictor [mm]	Boost ratio @ max Power [-]	DTM Car Weight [kg]	BoP Ballast [kg]	Total Car Weight [kg]	Total with Driver [kg]
	R8	2 x 37		1310	25	<b>1335</b>	<b><u>1415</u></b>
	M4		2.721	1310	0	<b>1310</b>	<b><u>1390</u></b>
	488		1.590	1295	35	<b>1330</b>	<b><u>1410</u></b>
	911	2 x 48		1275	5	<b>1280</b>	<b><u>1360</u></b>
	Huracan	2 x 41		1295	40	<b>1335</b>	<b><u>1415</u></b>
	GT3	2 x 36		1325	10	<b>1335</b>	<b><u>1415</u></b>
<b>Note:</b> 1. The DTM Car Weight includes the empty ballast box and the onboard camera. 2. The Total Car Weight includes the BoP Ballast.							



# DTM Race 8, Hockenheim

## BoP for P\_boost Ratio

<b>DTM</b>		<b>Balance of Performance, V1.0</b>		
		<b>DTM Race 8, Hockenheim</b>		
7. - 9. October 2022				
P_Boost ratio for Turbo Engines				
				
n	P_boost ratio		P_boost ratio	
3000	1.486		x	
3500	1.537		2.357	
4000	1.606		2.409	
4500	1.673		2.493	
5000	1.727		2.591	
5250	x		2.637	
5500	1.751		2.683	
5750	x		2.720	
6000	1.733		2.724	
6250	x		2.721	
6500	1.662		2.648	
6750	x		2.528	
7000	1.590		2.394	
7500	1.539		x	

**Note:**

- The P\_boost ratio in the table has to be multiplied with the P\_Ambient pressure to get the P\_boost limits.
- P\_Ambient will be communicated by the Organisation.
- Boost pressure control like FIA strategy, see next figure.
- The interpolation between the breakpoints is linear.

© ITR GmbH 2022. All contents of the DTM BoP 2022 are subject to the intellectual property rights of ITR GmbH and may not be used as a whole or in parts by third parties e.g. other race series or ASNs without ITR GmbH's prior written consent. The BoP parameters were created by AVL for ITR GmbH on the basis of vehicle simulation for the relevant race tracks of the DTM season 2022.

# DTM Race 8, Hockenheim FIA Boost Control

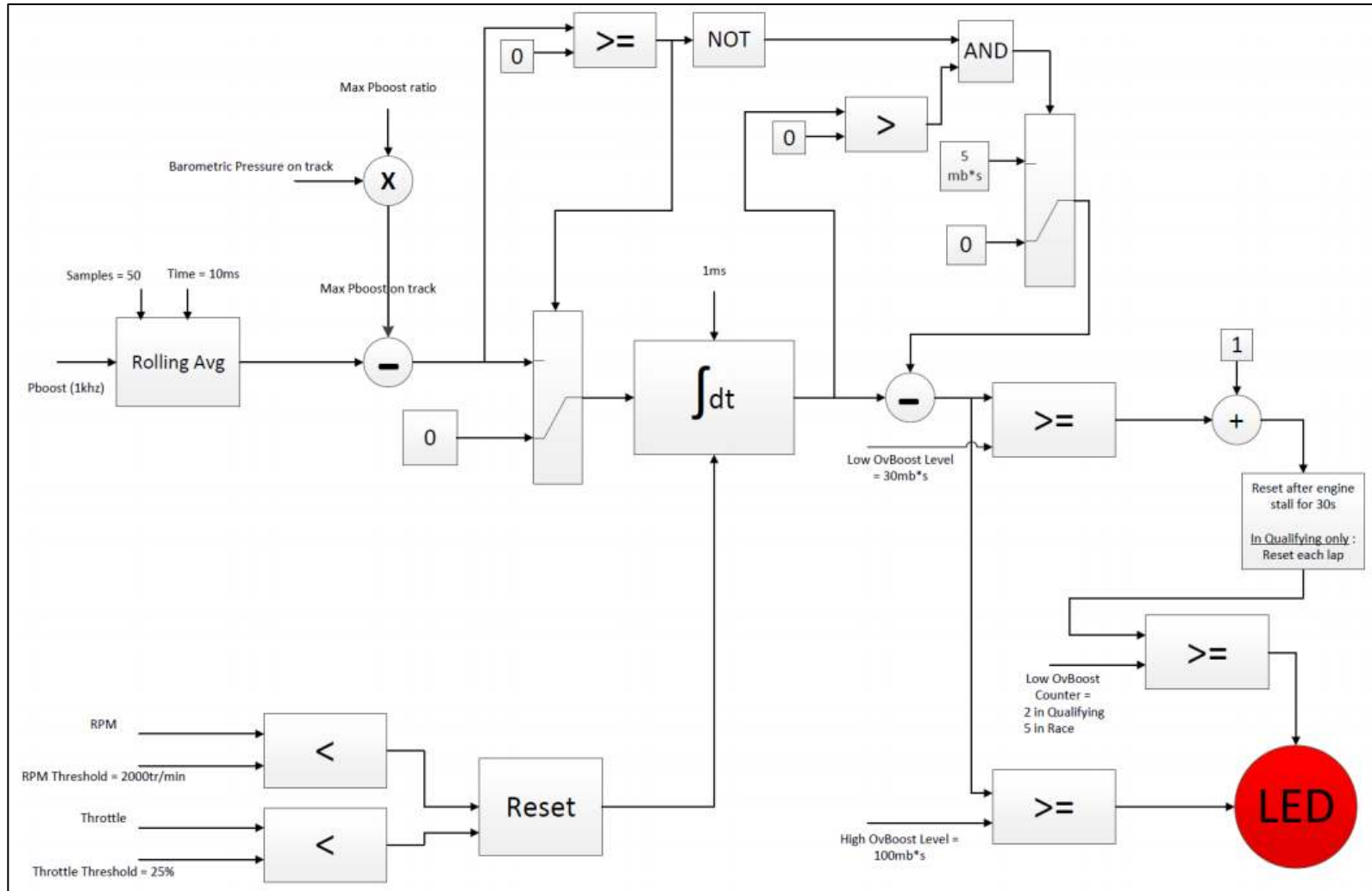

© ITR GmbH 2022. All contents of the DTM BoP 2022 are subject to the intellectual property rights of ITR GmbH and may not be used as a whole or in parts by third parties e.g. other race series or ASNs without ITR GmbH's prior written consent. The BoP parameters were created by AVL for ITR GmbH on the basis of vehicle simulation for the relevant race tracks of the DTM season 2022.