

Posted at: 12:00

DTM

Doc No.: 34

AVL
RACETECH

BoP (v3.0)

Race 5, Nürburgring

26. - 28. August 2022

Anton Schweinzer

DTM Race 5, Nürburgring General - Event and Track Information

Event:	DTM Race 5
Date:	26. - 28. August 2022

Track:	Nürburgring
Track Length:	3629m



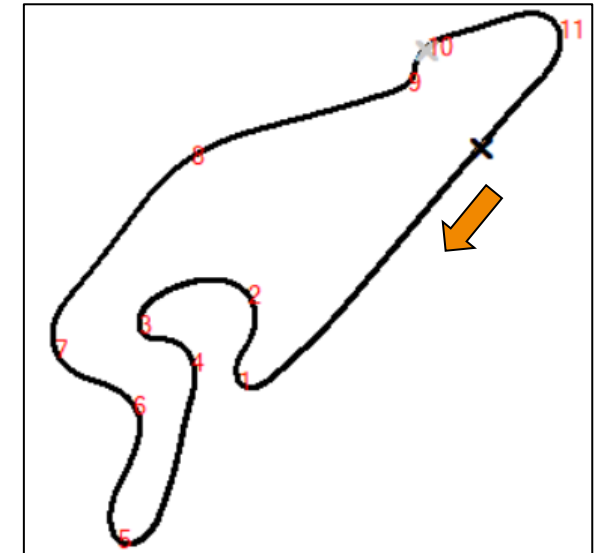



Race 1:	13:30, 27. August 2022
Race 2:	13:30, 28. August 2022

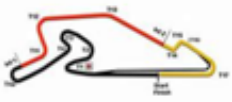
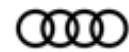

DTM Race 5, Nürburgring



BoP for Engine and Car weight



DTM		Balance of Performance, V3.0				AVL RACETECH	
		DTM Race 5, Nürburgring					
26. - 28. August 2022							
Brand	Typ	Restrictor [mm]	Boost ratio @ max Power [-]	DTM Car Weight [kg]	BoP Ballast [kg]	Total Car Weight [kg]	Total with Driver [kg]
	R8	2 x 37		1310	35	1345	<u>1425</u>
	M4		2.741	1310	0	1310	<u>1390</u>
	488		1.590	1295	35	1330	<u>1410</u>
	911	2 x 48		1275	5	1280	<u>1360</u>
	Huracan	2 x 41		1295	55	1350	<u>1430</u>
	GT3	2 x 36		1325	5	1330	<u>1410</u>
Note: 1. The DTM Car Weight includes the empty ballast box and the onboard camera. 2. The Total Car Weight includes the BoP Ballast.							



DTM Race 5, Nürburgring BoP for P_boost Ratio

DTM		Balance of Performance, V3.0		AVL RACETECH
 DTM Race 5, Nürburgring				
26. - 28. August 2022				
P_Boost ratio for Turbo Engines				
				
n	P_boost ratio		P_boost ratio	
3000	1.486		x	
3500	1.537		2.357	
4000	1.606		2.409	
4500	1.673		2.493	
5000	1.727		2.591	
5250	x		2.637	
5500	1.751		2.683	
5750	x		2.728	
6000	1.733		2.740	
6250	x		2.741	
6500	1.662		2.668	
6750	x		2.549	
7000	1.590		2.414	
7500	1.539		x	

Note:

- The P_boost ratio in the table has to be multiplied with the P_Ambient pressure to get the P_boost limits.
- P_Ambient will be communicated by the Organisation.
- Boost pressure control like FIA strategy, see next figure.
- The interpolation between the breakpoints is linear.

DTM Race 5, Nürburgring FIA Boost Control

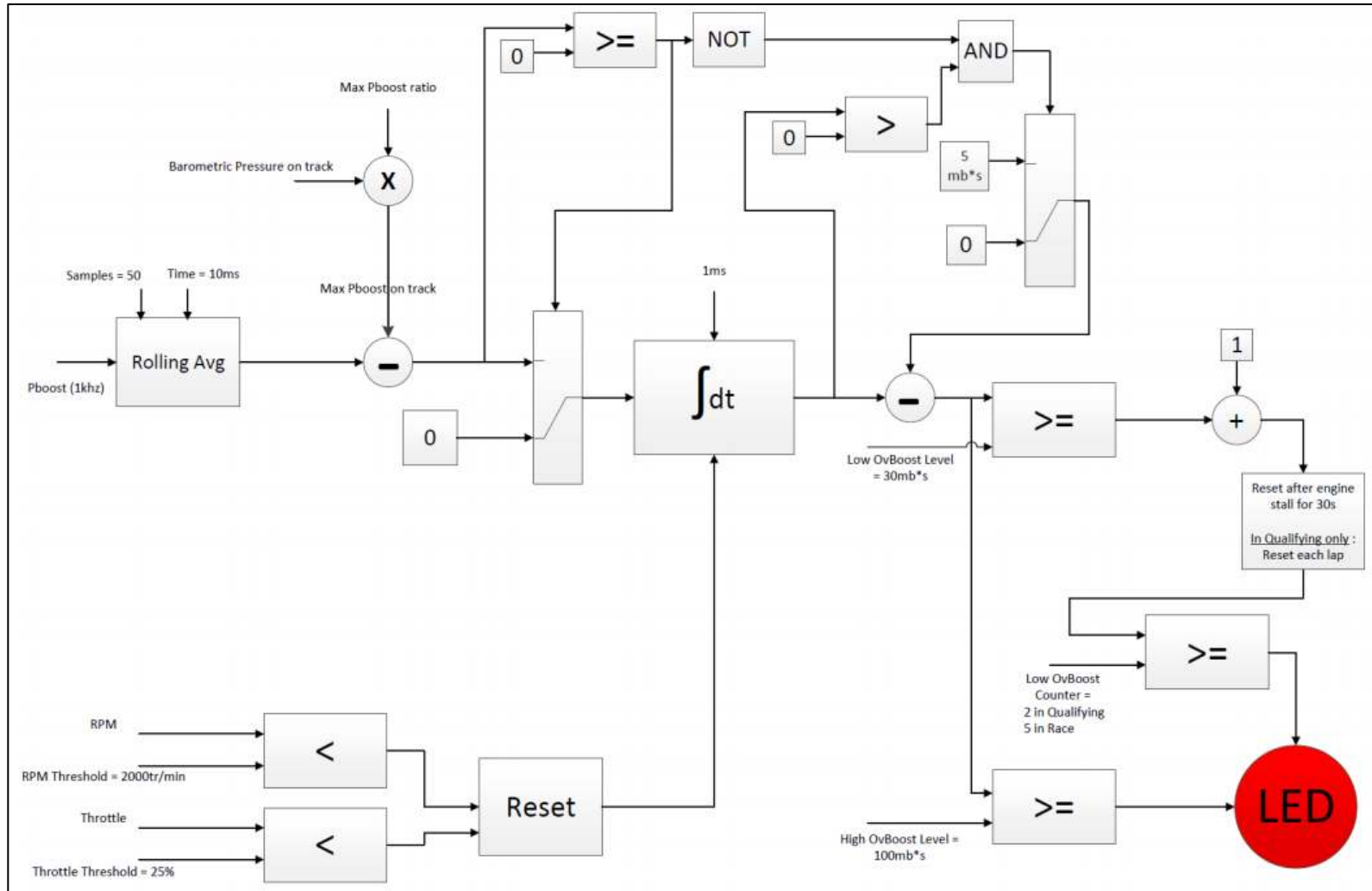

© ITR GmbH 2022. All contents of the DTM BoP 2022 are subject to the intellectual property rights of ITR GmbH and may not be used as a whole or in parts by third parties e.g. other race series or ASNs without ITR GmbH's prior written consent. The BoP parameters were created by AVL for ITR GmbH on the basis of vehicle simulation for the relevant race tracks of the DTM season 2022.